

**TYPICAL SECTION** *PARKING STRUCTURE*

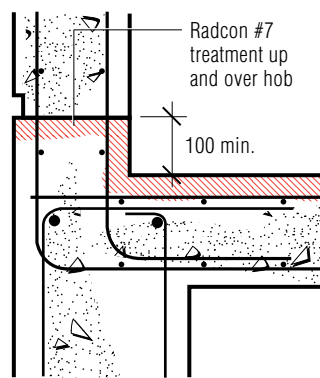

**DETAIL PPJ2**  
*CONSTRUCTION JOINT*

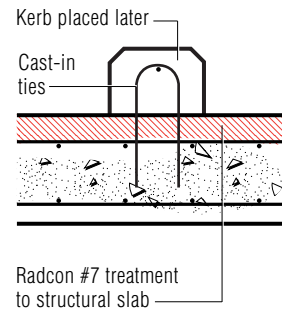

**DETAIL PM1**  
*KERB*

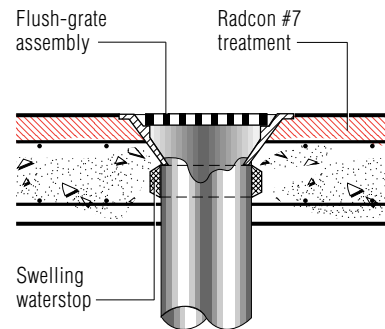

**DETAIL PP3**  
*PENETRATION*

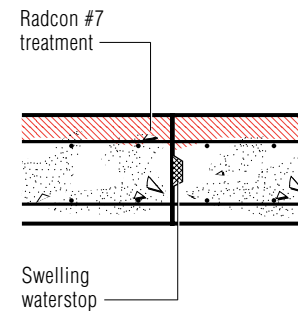

**DETAIL PPJ1**  
*CONSTRUCTION JOINT*

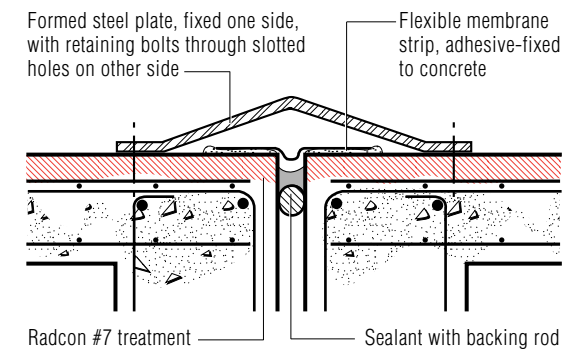

**DETAIL PEJ1**  
*EXPANSION JOINT*